

S 50 MANUAL

					**
MISURE PxLxA	TxBxH	PxAxA	DxWxH	MéXSzéXMa	660x500xh1500mm
DIMENSIONE VASCA	TANKABMESSUNG	DIMENSIÓN DEL TANQUE	TANKDIMENSION	TARTÁLY MÉRETEI	600x500xh450
PESO	GEWICHT	PESO	WEIGHT	ÖNSÚLY	55 kg
CARICO	ULTIMATE KAPAZITÄT	CAPACIDAD DE CARGA	LOAD CAPACITY	TERHELHETŐSÉG	15 kg
ALIMENTAZIONE	ENERGIE	ALIMENTACION	SUPPLY	LEVEGŐELLÁTÁS	6/10 bar
SPORTELLO CABINA	KABINENTÜR	PUERTA CABINA	CABIN DOOR	SZIVATTYÚ TELJ.	Optional
LAVAGGIO AUTOMATICO	AUTOMATISCHES WASCHEN	LADO AUTOMATICO	AUTOMATIC	KABINAJTÓ	NO
ASPIRAZIONE VENTURI	VENTURES	VENTURI	VENTURI	AUTOMATA	YES
FUSTINO	FUSTINE	TAMBORES	SERVICE BARREL	VENTURI ELSZÍVÁS	NO
GRIGLIA APPOGGIO	UNTERSTÜTZUNGSGITTER	REJILLA DE TRABAJO	WORKING GRID	SZERVÍZHORDÓ	YES
PENNELLO	BURSTE	BROCHA	BRUSH	MUNKARÁCS	YES
CERTIFICAZIONE	ZERTIFIZIERUNGEN	CERTIFICADA	CERTIFICATE	KEFE	ATEX II 3 G
POMPA PNEUMATICA	PNEUMATISCHE PUMPE	BOMBA NEUMÁTICA	PNEUMATIC PUMP	TANÚSÍTVÁNY	YES
VALVOLA SCAMBIO	SCHMUTZWECHSELVENTIL	VÁLVULA DE CAMBIO	DIRT-CLEAN VALVE	PNEUMATIKUS SZIVATTYÚ	NO
PISTOLA ARIA	SPRITZPISTOLE	PISTOLA AIRE	AIR GUN	LEENGEDŐSZELEP	YES
FILTRAGGIO	FILTER	FILTRO	FILTER	LEVEGŐPISZTOLY	YES
FLOCULAZIONE	FLOCKUNG	FLOCULACIÓN	FLOCCULATION	SZŰRŐ	NO
NEBULIZZATO	NEBULISIERT	PULVERIZACIÓN	NEBULIZED	PELYHESÍTŐ	YES
RISCIAQUO	SPÜLEN	ACLARADO	RINSING	ÖBLÍTÉS	NO
IMBALLO	VERPACKUNG	BULTO	PACKAGING	CSOMAGOLÁS MÉRETE	780x790xh1700 kg 60
CODICE	CODE	CÓDIGO	CODE	CIKKSZÁM	P10024.1

It: **Dati tecnici non vincolanti e modificabili senza preavviso. La società si riserva di apportare modifiche in qualsiasi momento

En: **Non-binding technical data that can be modified without notice. The company reserves the right to make changes at any time

Es: **Datos técnicos no vinculantes que pueden ser modificados sin previo aviso. La empresa se reserva el derecho a realizar cambios en cualquier momento.

Hu: **Nem kötelező érvényű műszaki adatok, amelyek előzetes értesítés nélkül módosíthatók. A társaság fenntartja a jogot, hogy bármikor változtatásokat hajtson végre.

De: **Die technischen Daten sind unverbindlich und können ohne Vorankündigung geändert werden. Das Unternehmen behält sich das Recht vor, jederzeit Änderungen vorzunehmen

Pentasol Hungary Kft. Székhely: 4030 Debrecen, Galamb utca 16.

Weboldal: www.pentasol-alkatreszmosas.hu, E-mail: info@pentasol.hu

Telefon: +36 20 214 6660

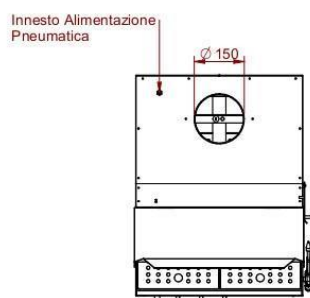
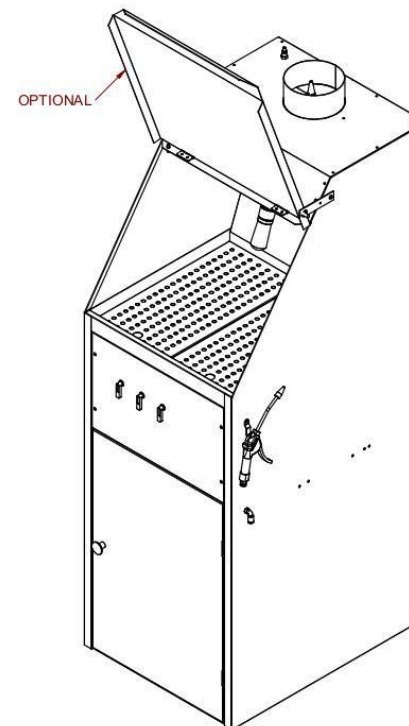
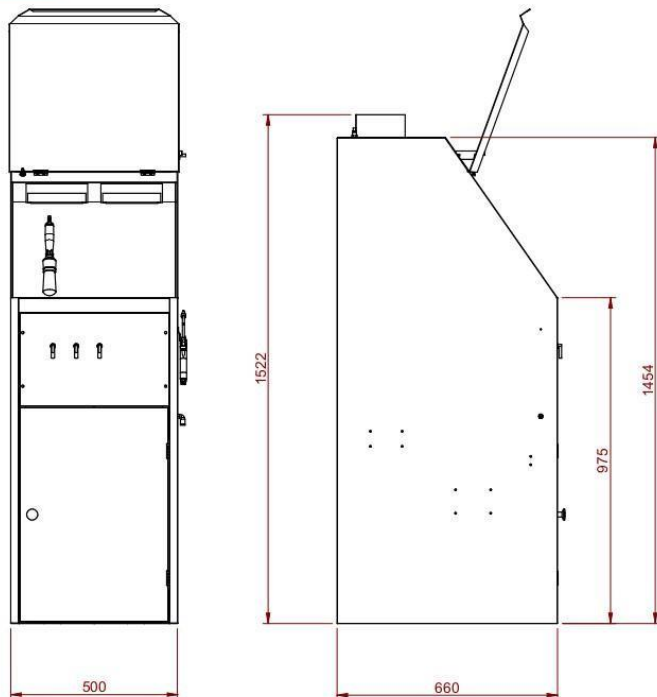

Dimensioni (H*L*P) : 1525x500x660 mm
Dimensioni vasca lavoro : 500x470mm
Alimentazione Pneumatica 6/10 bar